



FOR P.V.C. PIPES & FITTINGS <sup>®</sup>

# AGM U.PVC & CPVC FITTINGS



ARABIAN GULF MANUFACTURERS LTD., was established in the year 1965 as a first plastic processor in the Kingdom. Since then , we have become a part of the life of our valuable customers. Thirty three years of rich experience as well as our R&D has made us a pioneer in the field of plastic processing in the entire Gulf region. Our immaculate product quality gained us the confidence of our valuable customers internationally.

As one of the leading and the largest plastic processors in the Kingdom, our CPVC and UPVC pipes and fittings, used for domestic and industrial purposes, conform to the international standards, like ASTM, DIN, BS and SASO. Our PVC pipes and fittings are widely used by the world's renowned contractors in their prestigious projects locally in the neighbouring countries.

Our other range of products include thermoformed disposable items, injection molded housewares, blow molded household and industrial purpose jerry-cans, polycarbonate water bottles,shampoo bottles, printed and unprinted shopping and packing bags,stretch film for wrapping purpose, cling film for food wrapping, masterbatches for other plastic processors, industrial sheets used in the lighting, construction and refrigeration industries.

We have all these processing facilities under the cover of one roof. This is fairly unique and first of this type in the entire Gulf region. More importantly, in brief, we are committed to live through the needs of our valuable customers at all times.

#### MANAGEMENT RESPONSIBILITY AND QUALITY POLICY :

- a- We are committed to assess the quality of raw materials, semifinished goods and the final products at various stages of the production process.
- b- We are committed to ensure that the whole production process operates according to the desired set standard and in case of any deviations, necessary corrective measures are to be taken.
- c- We are committed to suggest measures and plans to improve the standard of goods produced without much cost escalation.
- d- We are committed to develop quality consciousness among the various sections of our industrial units.
- e- In brief, we are committed to ensure the quality standard of the finished products.



### ELBOW 90°

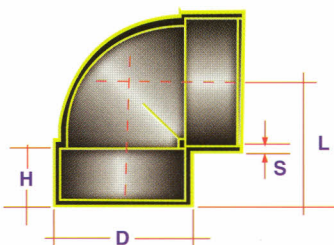

SIZE Inch	D mm	L mm	S mm	H mm
1/2"	29.85	36.52	4.23	23.02
3/4"	35.54	41.27	4.41	26.19
1"	43.56	48.42	5.05	29.77
1 1/4"	52.93	56.36	5.35	32.94
1 1/2"	60.4	62.5	5.9	36.0
2"	73.2	69.5	6.25	38.0

### COUPLING

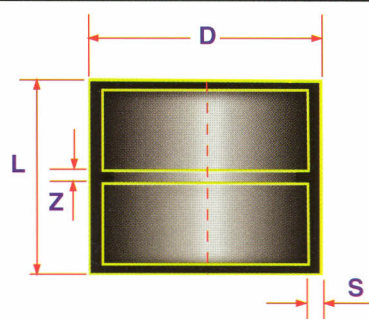

SIZE Inch	D mm	L mm	S mm	Z mm
1/2"	29.85	45.21	4.23	3.18
3/4"	35.54	55.56	4.41	3.18
1"	43.56	62.71	5.05	3.18
1 1/4"	52.93	69.06	5.35	3.18
1 1/2"	59.5	76.5	5.45	4.5
2"	72.8	84.2	6.05	8.2

### TEE eq. 90°

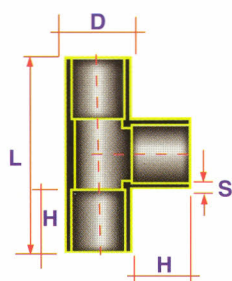

SIZE Inch	D mm	L mm	S mm	H mm
1/2"	29.85	73.03	4.23	23.02
3/4"	35.54	82.55	4.41	26.19
1"	43.56	96.84	5.05	29.77
1 1/2"	59.0	121.7	5.2	36
2"	73.2	139	6.25	38

### MALE ADAPTOR

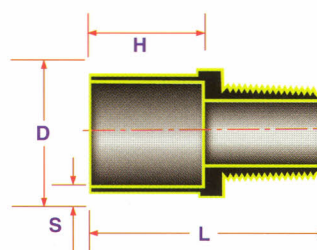

SIZE Inch	D mm	L mm	S mm	H mm
1/2"	29.85	47	4.23	23.02
3/4"	35.54	52.5	4.41	26.19
1"	43.56	61.5	5.05	29.77
1 1/4"	53.0	65.3	5.25	31.0



### RED. BUSHING

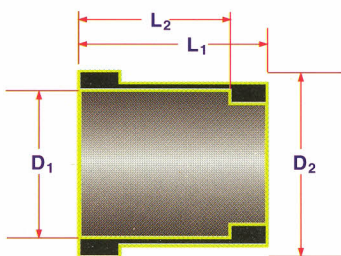

SIZE Inch	L1 mm	L2 mm	D1 mm	D2 mm
3/4"x1/2"	27.5	22.2	21.6	26.7
1" x 3/4"	33.7	25.6	27	33.5

### END CAP

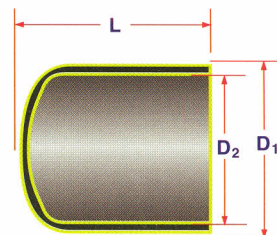

SIZE Inch	L mm	D1 mm	D2 mm
1/2"	31.5	29.5	21.6
3/4"	35.3	34.8	27

### UNION

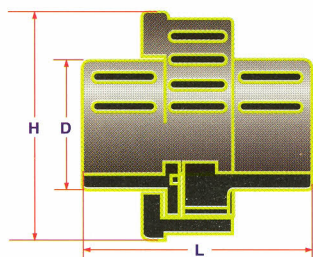

SIZE Inch	L mm	H mm	D mm
3/4"	68.8	64.0	27
1"	71.6	74.0	33.7

### Tee Brass insert

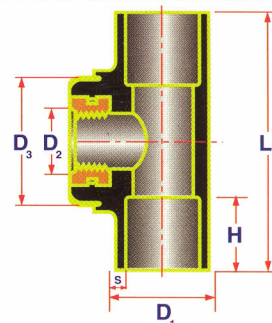

SIZE Inch	D <sub>1</sub> mm	D <sub>2</sub> Inch	D <sub>3</sub> mm	H mm	S mm	L mm
1/2"x1/2"	30.45	0.5	38	22.95	4.45	78.00
3/4"x1/2"	36.1	0.5	38	25.95	4.55	80.00

### ELbow Brass insert 90°

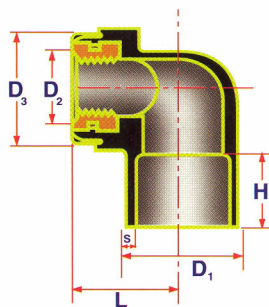

SIZE Inch	D <sub>1</sub> mm	D <sub>2</sub> Inch	D <sub>3</sub> mm	H mm	S mm	L mm
1/2"x1/2"	30.45	0.5	38	22.45	4.4	28
3/4"x1/2"	36.1	0.5	38	22.95	4.5	33

### ELBOW 90°

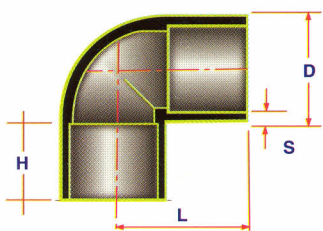

SIZE Inch	D mm	L mm	S mm	H mm
1/2"	27.92	31.76	3.27	18.27
3/4"	33.46	34.14	3.37	19.06
1"	41.22	42.07	3.88	23.42
1 1/4"	50.34	48.44	4.06	25.02
1 1/2"	56.7	56.37	4.18	29.36
2"	69.22	64.29	4.41	39.95

### TEE eq. 90°

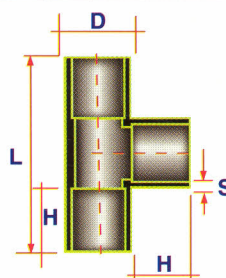

SIZE Inch	D mm	L mm	S mm	H mm
1/2"	27.92	63.53	3.27	18.27
3/4"	33.46	68.28	3.37	19.06
1"	41.22	84.14	3.88	23.42
1 1/4"	50.34	96.85	4.06	25.02
1 1/2"	56.7	112.73	4.18	29.36
2"	69.22	128.57	4.41	30.95

### ELBOW 45°

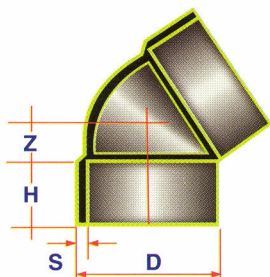

SIZE Inch	D mm	Z mm	S mm	H mm
1 1/2"	56.5	11	3.95	32
2"	69	17	4.15	33

### MALE ADAPTOR

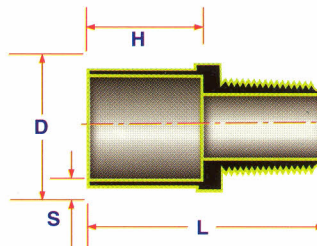

SIZE Inch	D mm	L mm	S mm	H mm
1/2"	27.92	41.5	3.27	18.27
3/4"	33.46	44.6	3.37	19.06
1"	41.22	54.5	3.88	23.42
1 1/4"	56.7	64.0	4.18	29.38

### COUPLING

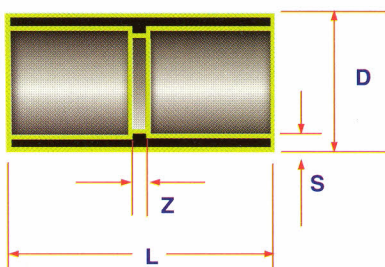

SIZE Inch	D mm	L mm	S mm	Z mm
1/2"	27.92	39.71	3.27	3.18
3/4"	33.46	41.29	3.37	3.18
1"	41.22	50.01	3.88	3.18
1 1/4"	50.34	53.2	4.06	3.18
1 1/2"	56.7	61.91	4.18	3.18
2"	69.22	65.07	4.41	3.18



### COUPLING

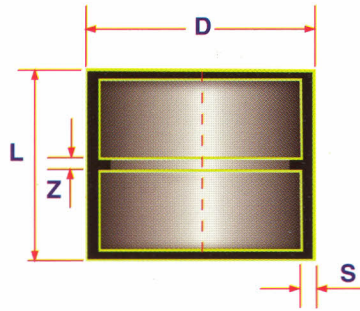

SIZE Inch	D mm	L mm	S mm	Z mm
3"	101.5	100.0	5.79	4.76
4"	127.8	106.5	6.32	4.76
6"	184.1	157.4	7.46	5.0

### ELBOW 90°

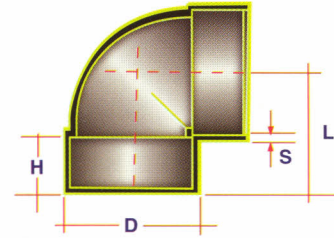

SIZE Inch	D mm	L mm	S mm	H mm
3"	99.7	94.4	5.15	48.13
4"	126.8	110.0	5.50	51.30
6"	180.5	168.5	5.9	80.0

### ELBOW 45°

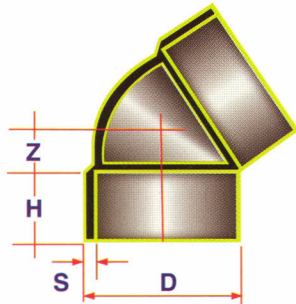

SIZE Inch	D mm	Z mm	S mm	H mm
3"	99.7	23.53	5.15	48.13
4"	126.8	25.65	5.5	51.30
6"	180.5	41.00	5.9	80.0

### TEE eq. 45°

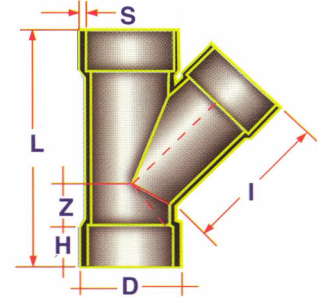

SIZE Inch	D mm	L mm	I mm	Z mm	S mm	H mm
4"	126.8	275.6	193.5	30.0	5.5	51.3
6"	180.5	410.4	286.4	44.0	5.9	80.0

### TEE eq. 45° with access cap

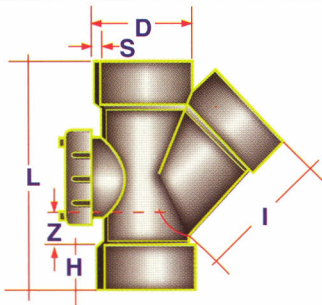

SIZE Inch	D mm	L mm	I mm	Z mm	S mm	H mm
4"	126.8	275.6	193.5	30.5	5.5	51.3

### RED TEE 45°

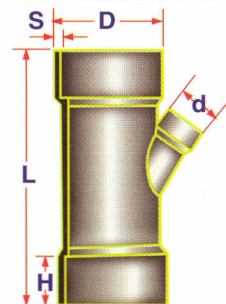

SIZE Inch	D mm	d mm	L mm	S mm	H mm
4" / 2"	126.8	68.7	275.6	5.5	51.3
6" / 4"	180.5	125.5	333.2	5.9	80.0

### SYPHON

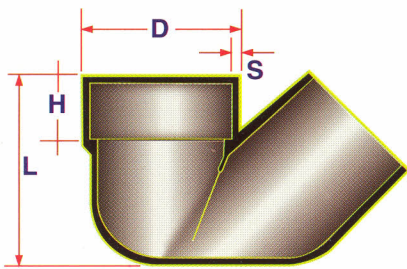

SIZE Inch	D mm	L mm	S mm	H mm
3"	100.0	124	5.35	47.65
4"	126.0	150	4.95	44.0

### TEE eq. 90°

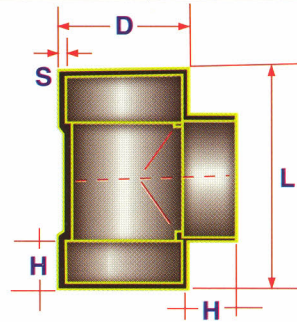

SIZE Inch	D mm	L mm	S mm	H mm
3"	99.7	94.4	5.15	48.13
4"	126.8	220.0	5.5	51.30
6"	180.5	337.00	5.9	80.0

### TEE eq. with access cap

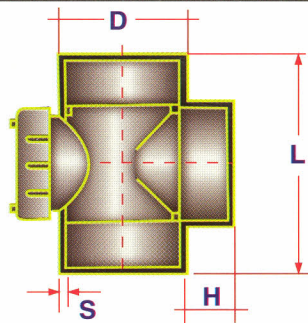

SIZE Inch	D mm	L mm	S mm	H mm
4"	126.8	220.6	5.5	51.30

### RED TEE

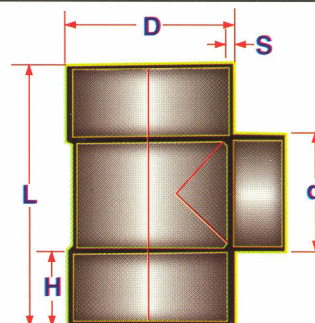

SIZE Inch	D mm	d mm	L mm	S mm	H mm
6" / 4"	180.5	125.5	283.0	5.9	80.0

### RED TEE 45° with access cap

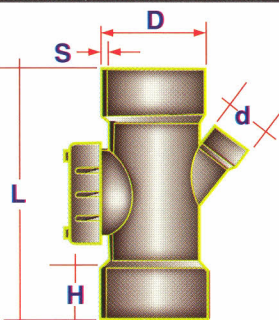

SIZE Inch	D mm	d mm	L mm	S mm	H mm
4" / 2"	126.8	68.7	275.6	5.5	51.3

### ELBOW 90° with access cap

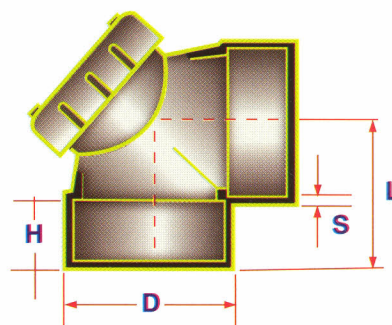

SIZE Inch	D mm	L mm	S mm	H mm
4"	126.8	110.00	5.50	51.30

### FLOOR TRAP

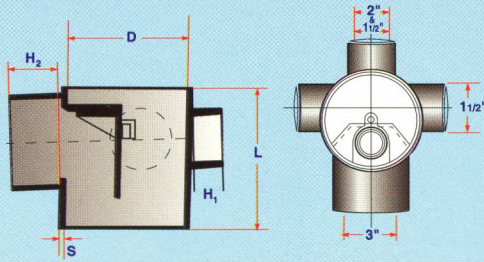

SIZE inches	D mm	L mm	S mm	H <sub>2</sub> mm	H <sub>1</sub> mm
OUTLET 3" INLET 1 1/2", 2"	120	144 117	3.35	48	28

### COVER SET

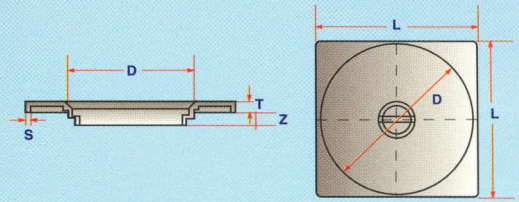

SIZE L X L (mm)	D mm	Z mm	T mm	S mm
150 x 150 200 x 200	122	12.0	10.0	5.0

### CLEANING INSERT W/ ACCESS CAP

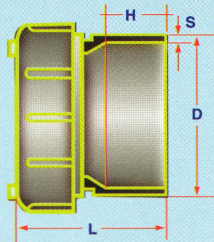

SIZE inches	D mm	L mm	S mm	H mm
4"	124.35	87	5.2	50.0

### P - TRAP = SYPHON + ELBOW 45°



SIZE inches	3" & 4"
----------------	---------

### SYPHON

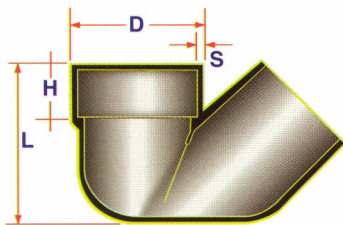

SIZE D.mm	D mm	L mm	S mm	H mm
110	110	150	45	4

### P - TRAP

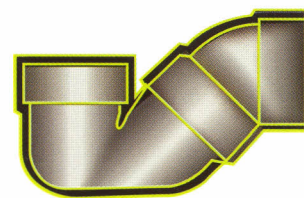

SIZE D.mm
110



## COUPLING

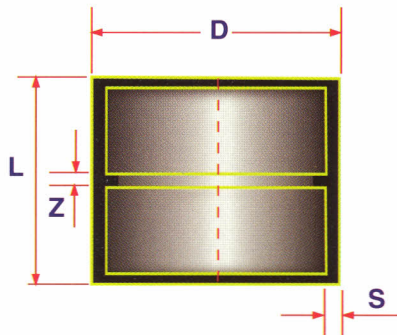

SIZE D.mm	D mm	L mm	S mm	Z mm
110	125.0	61.0	4.0	3.0
160	176.0	86.0	4.0	4.0

## ELBOW 87.5°

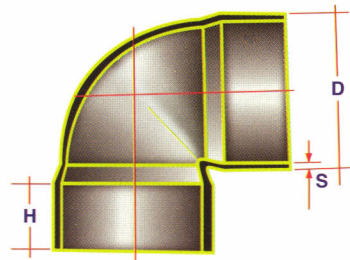

SIZE D.mm	H mm	S mm
110	61.0	2.7
160	86.0	3.2

## ELBOW 45°

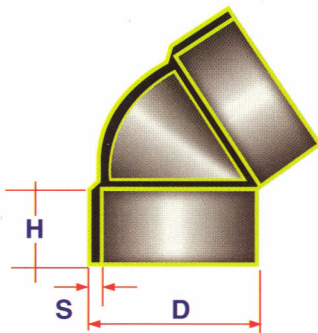

SIZE D.mm	H mm	S mm
110	61.0	4.0

## TEE eq. 87.5

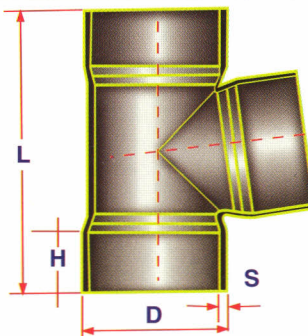

SIZE D.mm	D mm	L mm	S mm
110	257.4	61.0	2.7
160	347.0	86.0	3.2

## ELBOW 87.5 (Sewer)

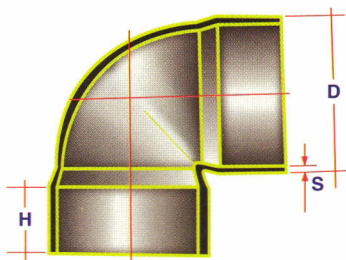

SIZE Inch	D mm	S mm	H mm
3"	95.5	3.15	40

## TEE eq. 87.5

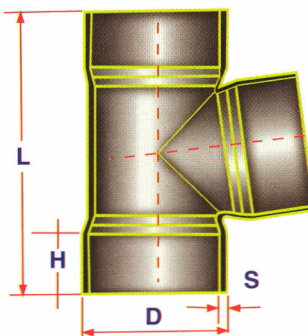

SIZE Inch	D mm	L mm	S mm	H mm
3"	95.5	194.0	3.15	40



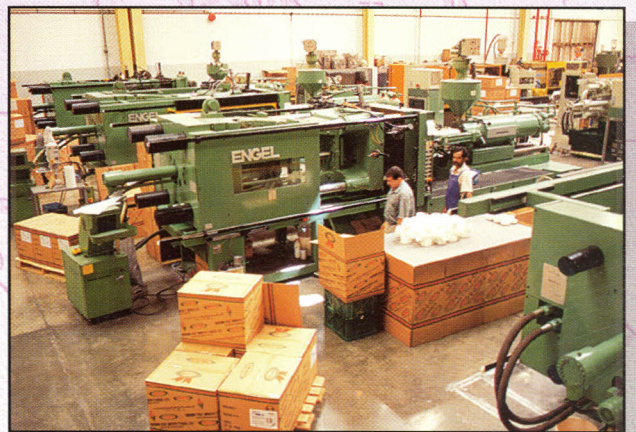
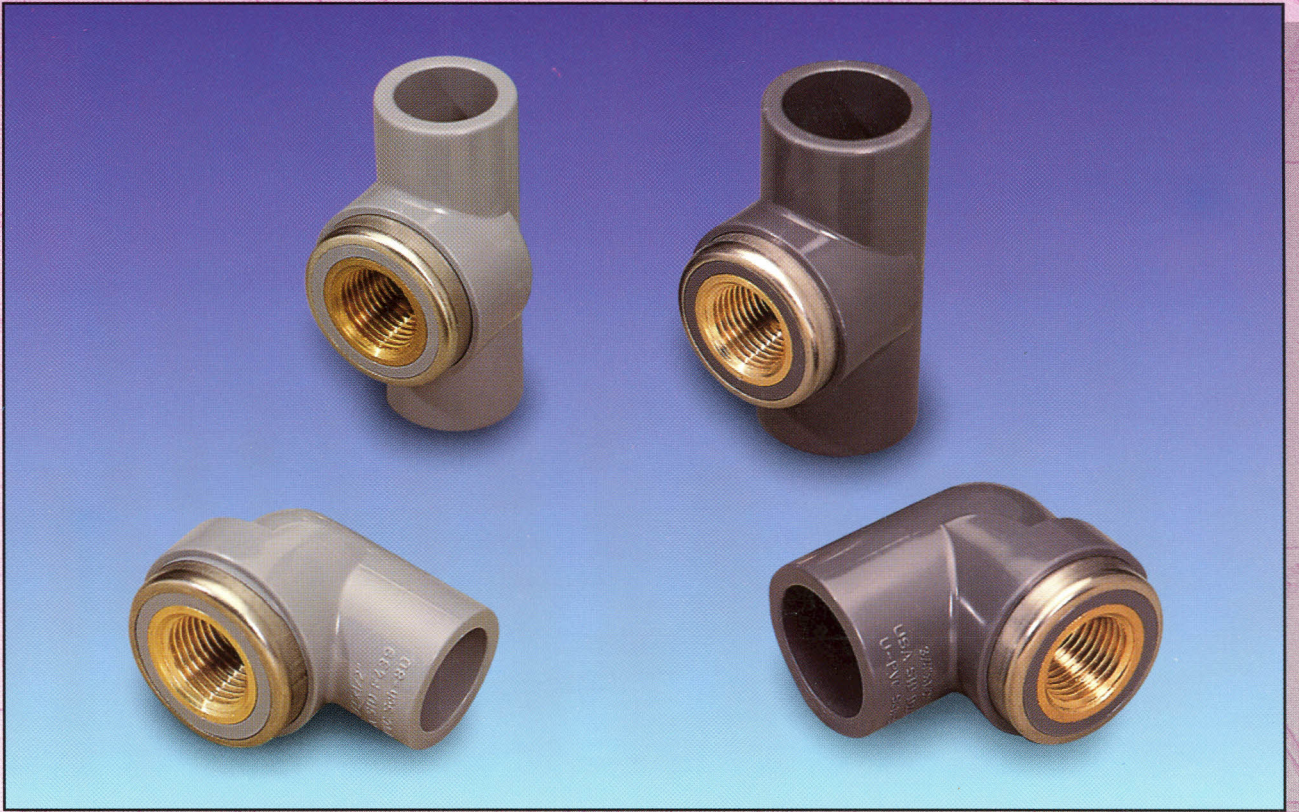
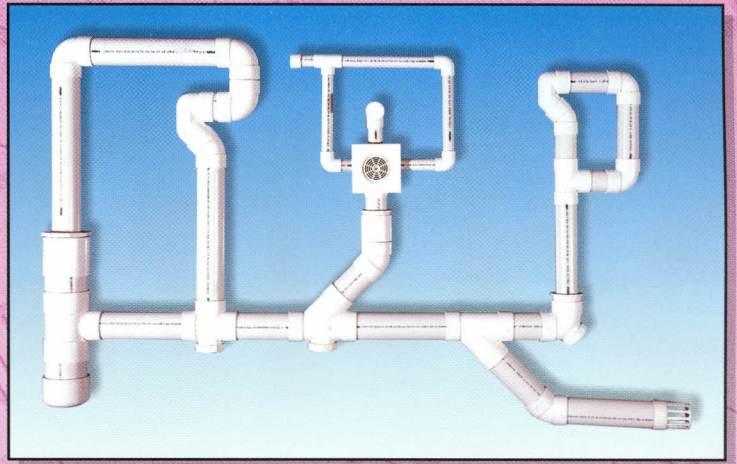
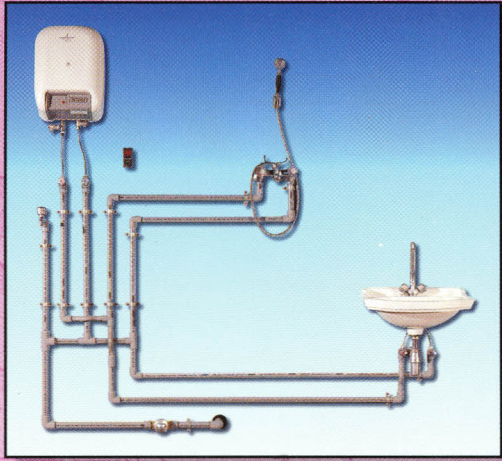

  
AGM FOR P.V.C.  
PIPES & FITTINGS





Ten silos for material distribution before mixing.



Production area with fifteen extruder machines.



View of Arabian Gulf Manufacturers Ltd. for Plastic industry. The new plant inaugurated in 1991, covering an area of 85.000 sq. m. : one of the most modern & largest plant in the Kingdom.

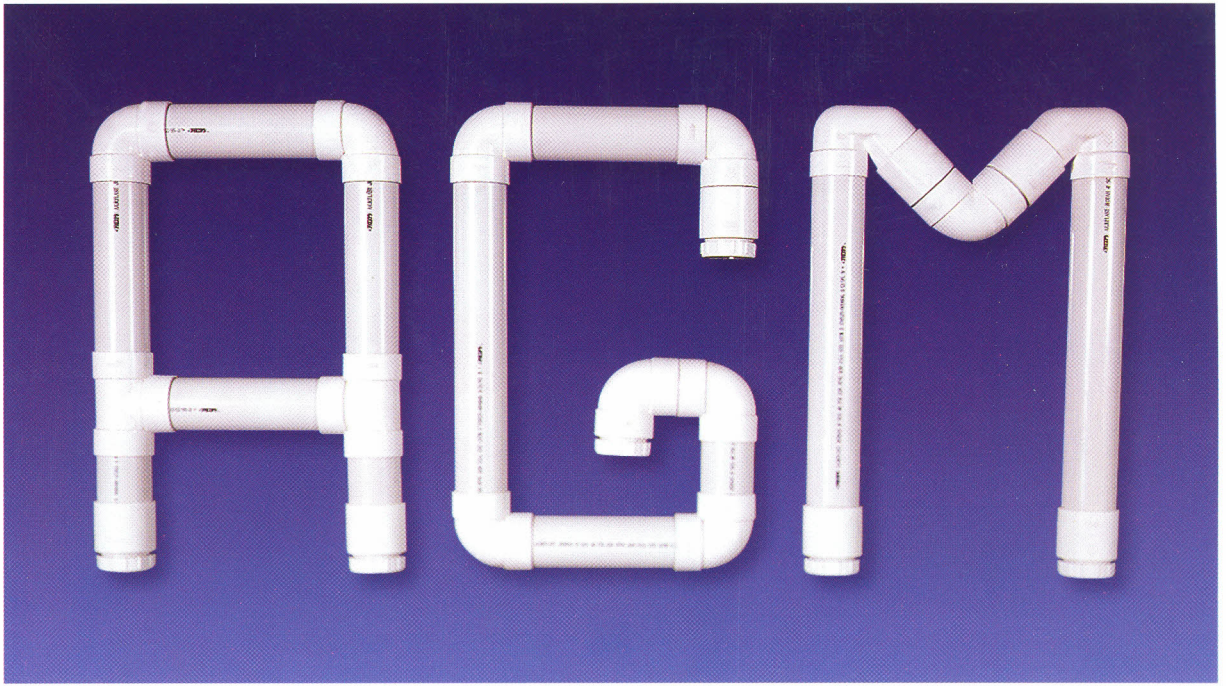

## ARABIAN GULF MANUFACTURERS LTD.

FOR PLASTIC INDUSTRY

Admin & Sales : Jeddah - Tel. 680 1416 - Direct 680 3484 - P.O.Box 2143 Jeddah 21451  
Telex. 600229 PLASTC SJ - Fax. 688 3588

Factories : Jeddah - Industrial City - Tel. 637 7944 (5 Lines), 638 0545 (7 Lines)  
Fax. 638 0540

Branches : Jeddah : Tel. 24493 - 691 1712  
Riyadh : Tel. 403 6160 - 446 3312  
Dammam : Tel. 834 0472 - 833 8243  
Yanbu : Tel. 322 6673  
Madina : Tel. 826 7542  
Qasim : Tel. 323 0792  
Kh.Mushait : Tel. 223 3543  
Tabuk : Tel. 423 8861

## شركة مصانع الخليج العربي المحدودة

للصناعات البلاستيكية

الإدارة والمبيعات : جدة - ت ٦٨٠١٤١٦ - مباشر ٦٨٠٢٤٨٤ - ص ب ٢١٤٣ جدة ٢١٤٥١  
تلكس ٦٠٠٢٢٩ - بلاستيك أس جي - فاكس ٦٨٨٣٥٨٨

المصانع : جدة - المدينة الصناعية - ت ٦٣٧٧٩٤٤ (٥ خطوط), ٦٣٨٠٥٤٥ (٧ خطوط)  
فاكس ٦٣٨٠٥٤٠

الفرع : جدة : ت ٦٤٣٤٤٩٣ - ٦٩١ ١٧١٢  
الرياض : ت ٤٠٣٦١٦٠ - ٤٤٦٣٣١٢  
الدمام : ت ٤٧٢ - ٨٢٤ - ٨٢٣ ٨٢٤٣  
ينبع : ت ٢٢٢ ٦٦٧٣  
المدينة : ت ٨٢٦ ٧٥٤٢  
القصيم : ت ٧٩٢ - ٢٢٣  
خميس مشيط : ت ٣٥٤٣ - ٢٢٣  
تبوك : ت ٨٨٦١ - ٤٢٣